



DOT R27 OVAL

ΠΕΡΙΕΧΟΜΕΝΑ / CONTENTS

DATASHEET1
 MANUAL2

SKU: **DT270-** XX-XX-XX-XX-XX-XX

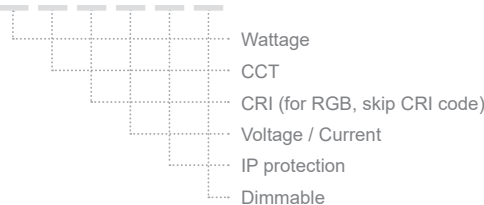

DOT R27 OVAL (DT270-) / Datasheet

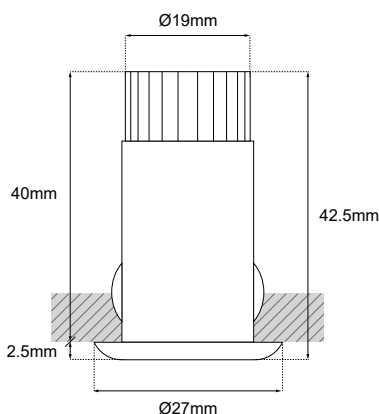

GENERAL INFORMATION

APPLICATION	Ceiling or Wall / Recessed
MATERIAL	Polycarbonate
INCL. CABLE	10cm
ELECTRIC GEAR	Not Included
WEIGHT	20gr
ORIGIN	Greece

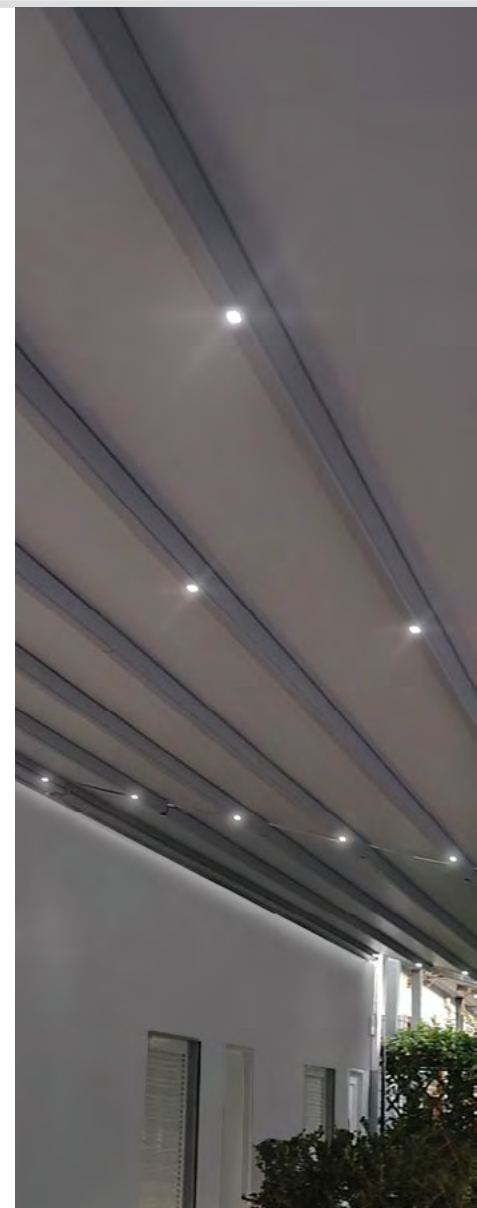

Wattage	Voltage / Current	CCT	CRI	IP	Dimmable
1W (1W) 2.5W* (2.5W) *IP65-20 only	12V (V1)	2700K (120Lm/w) (27K)	Ra80 (80)	IP20 (20)	Dim (D)
	24V (V2)	3000K (130Lm/w) (30K)	Ra90 (90)		No Dim (L)
	350mA (1W) (V4)	4000K (140Lm/w) (40K)	(R) / (G) / (B) / (A)	Front: IP65 / Back: IP20 (65-20)*	IP65 (65)
		6000K (145Lm/w) (60K)			
	RGB (C1)	RGB (C1)	IP68 (68)	IP68 (68)	

*** Caution:**
 The IP65 protection only applies to the specific area of the luminaire.

*** Προσοχή:**
 Η στεγανότητα IP65 ισχύει μόνο για τη συγκεκριμένη περιοχή του φωτιστικού

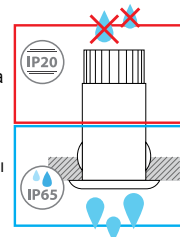

Δημιουργία Κωδικού προϊόντος / Product Code generator
DT270 - wattage - CCT - CRI - voltage - IP - dimmable
 (ex. DT270-2.5W-V1-65-20-D for Dot R27 oval, 2.5W, 12V, IP65/IP20, dimmable)

DOT R27 OVAL / Manual

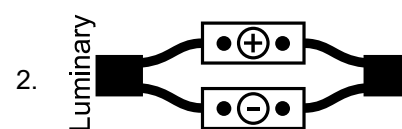
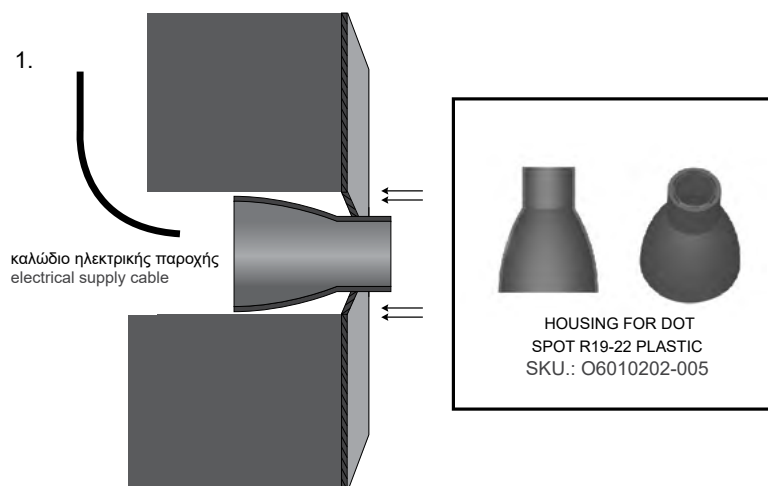

Συνδέστε το καλώδιο του φωτιστικού με την ηλεκτρική παροχή.
Η σύνδεση πρέπει να είναι στεγανή.

Connect the cable of the luminaire with the electrical supply.
The connection must be sealed.

3.a Εφαρμογή στον τοίχο Application in wall

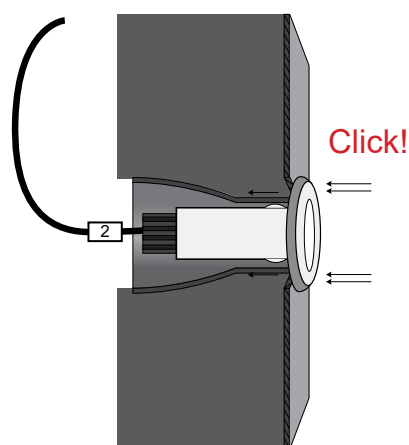

3.b Εφαρμογή σε γυψοσανίδα Application on plasterboard

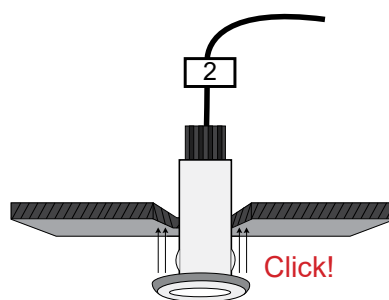

3.b Εφαρμογή σε πέργκολα αλουμινίου Application on aluminium pergola

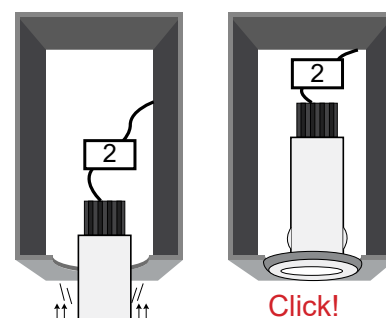

Εφαρμόστε το φωτιστικό στην οπή μέχρι να σφηνώσει και να σταθεροποιηθεί.

Apply the luminaire in the cutting hole until it is firm and stabilized.