

- 1. HR-LINE Profile (Ref. B3579)
- 2.1 Gland (item 2.1)*
- 2.2 Gland (item 2.1)*
- 3. End cap*
- 4. LED tape in sleeve with cable*
- 5. Cover*
- 6.1 Hermetic coupler (item 6.1)*
- 6.2 Hermetic coupler (item 6.2)*
- 6.3 Hermetic coupler (item 6.3)*
- 6.4 Hermetic coupler (item 6.4)*
- 7.1 Connector (item 7.1)*
- 7.2 Connector (item 7.2)*

OPTIONAL

*The full range of accessories and electronics is available at www.KlusDesign.com

NOTE! All LED tapes must be connected to a 12 V or 24 V power supply.

IMPORTANT: Not all possible mounting procedures are presented here. More mounting procedures and related accessories can be found at www.KlusDesign.com. Drawings of extrusions and accessories in these instructions are simplified and only approximate the actual shapes.

I

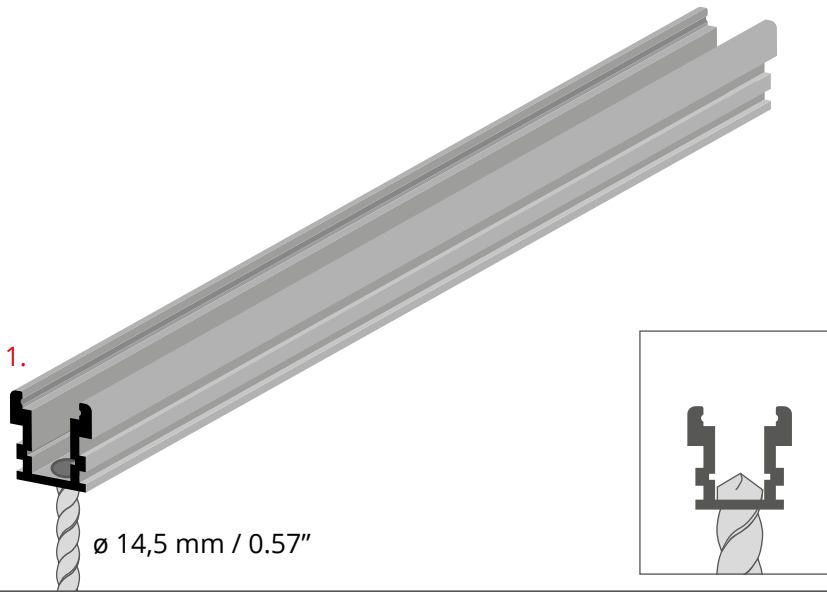

Drill a hole for the gland in the HR-LINE profile (1).

II

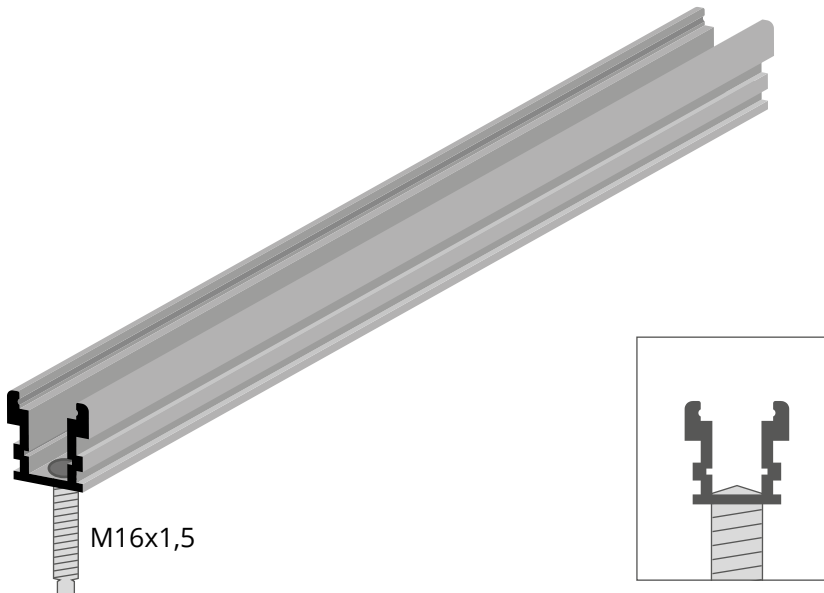

Thread the pre-drilled hole.

III

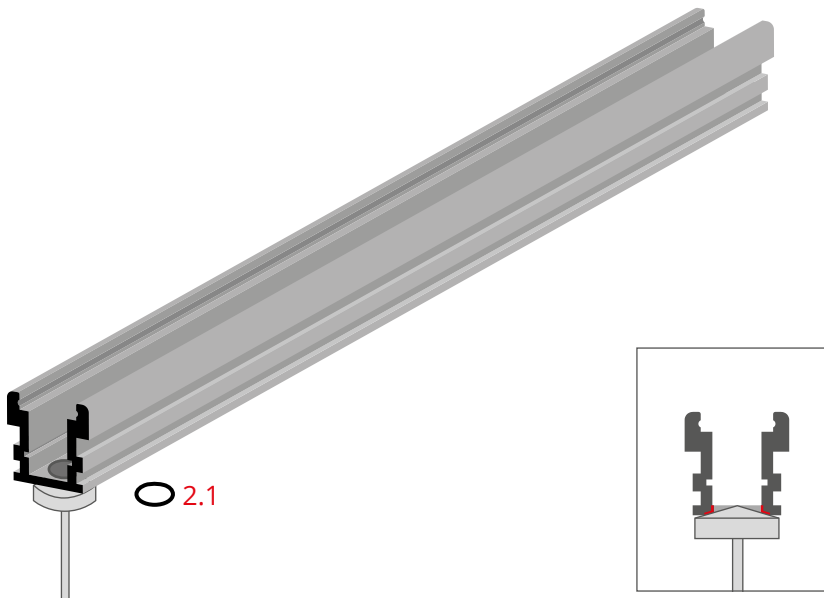

Chamfer the hole to hide the hermetic coupler item (2.1) in the recess.

IV

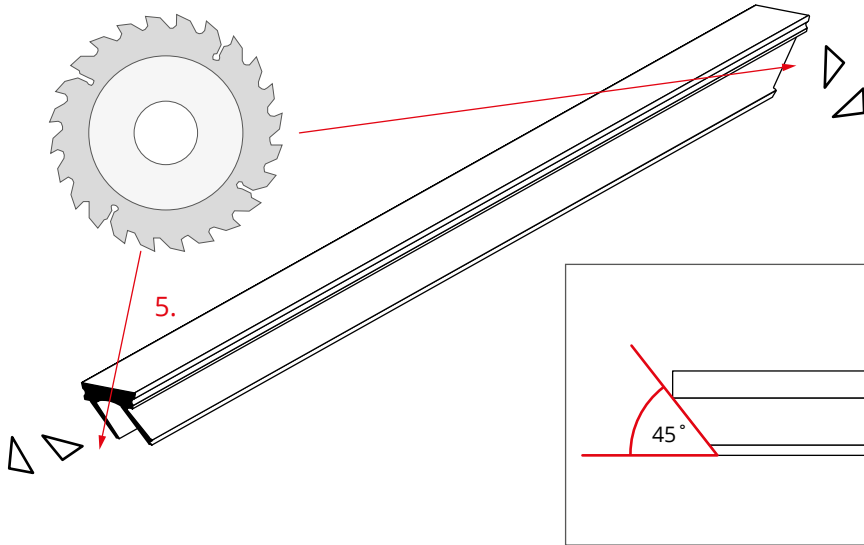

Cut the arms of the cover (5) at their ends at an angle of 45°.

V

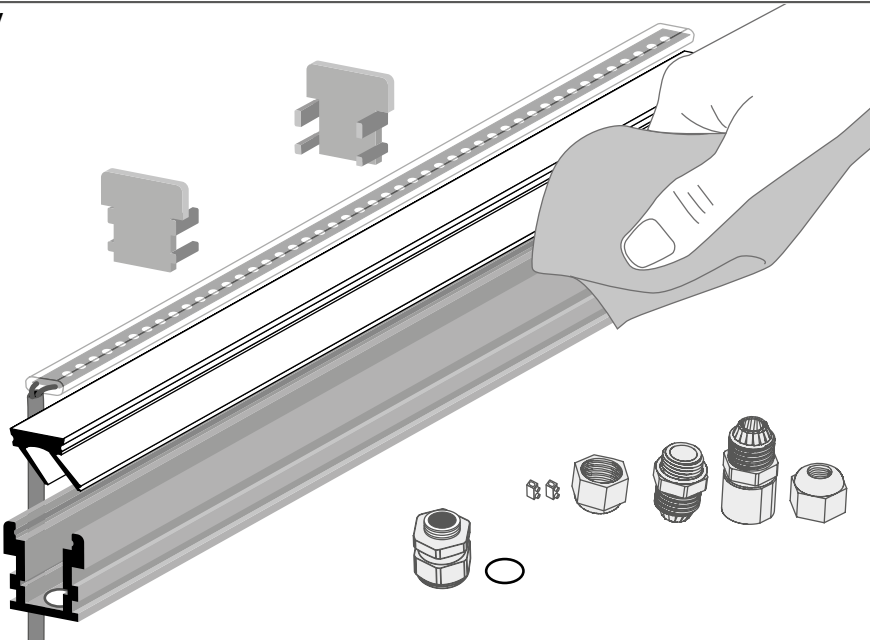

Clean all the elements of the fixture from dust and dirt.

VI

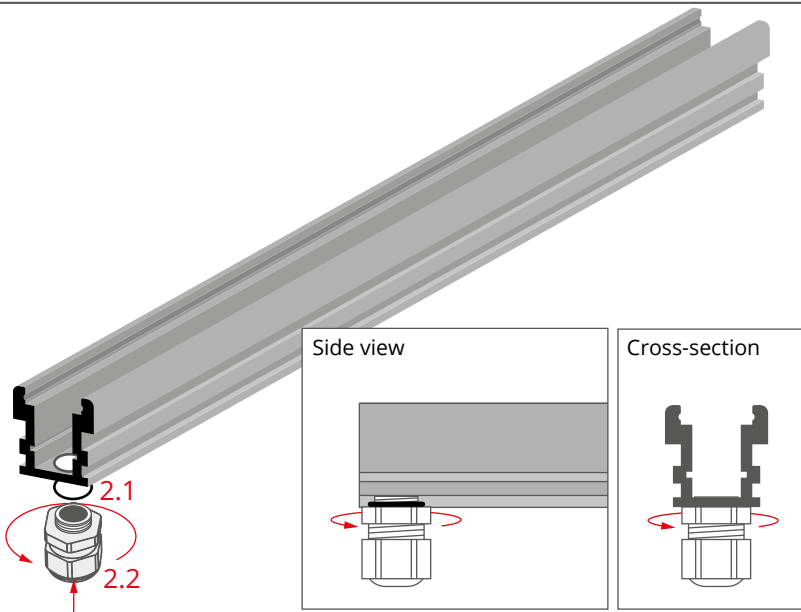

Place the hermetic coupler item (2.1) in the recess and screw item (2.2) in the hole.

VII

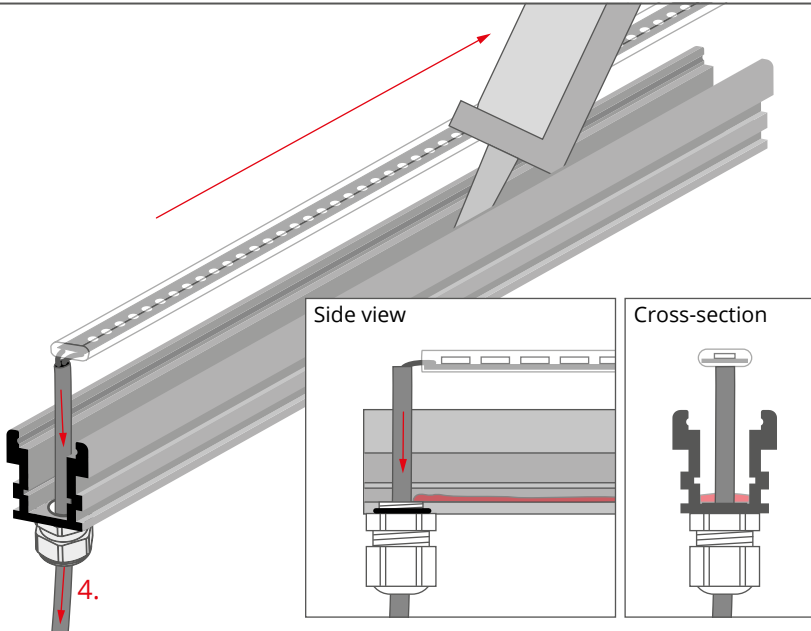

Lead the cable from the LED tape (4) through the gland.

Distribute a small portion of silicone on the bottom of the profile.

VIII

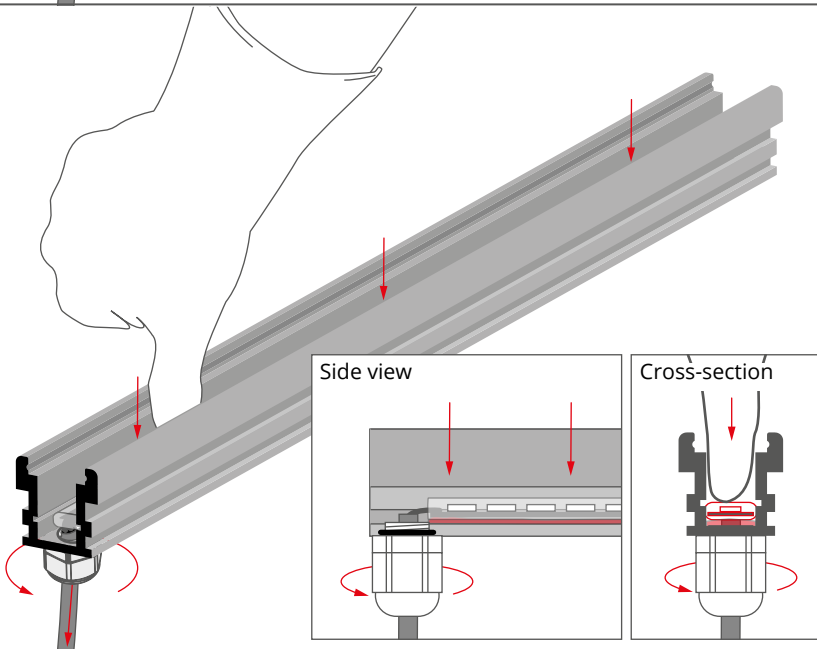

Press the LED tape to the bottom of the profile and tighten the gland.

IX

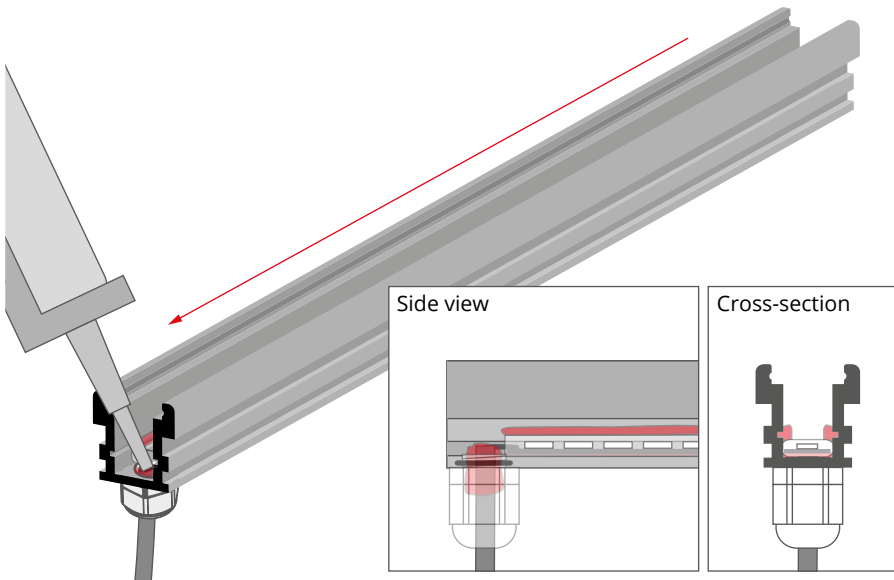

Fill the gland with silicone. Distribute silicone along the edges of the LED tape.

X

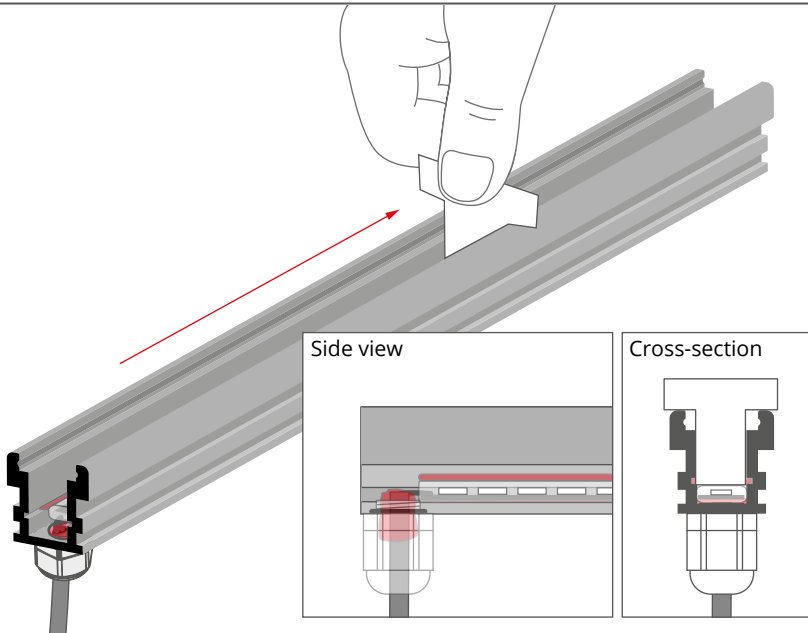

Level the layer of the silicone inside the profile.

XI

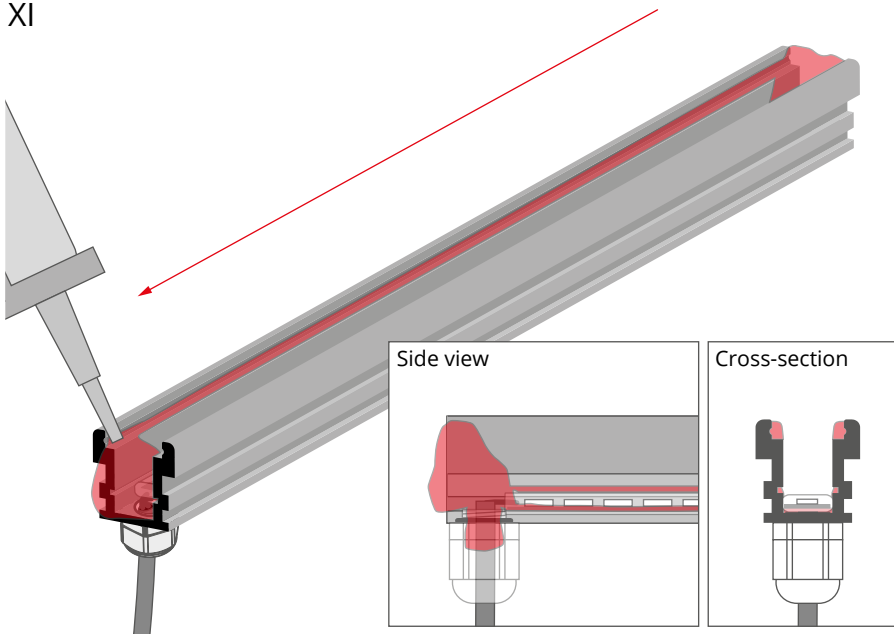

Fill the ends of the profile with silicone.
Run a bead of silicone along where the cover will sit and also where it will hook into the profile.

XII

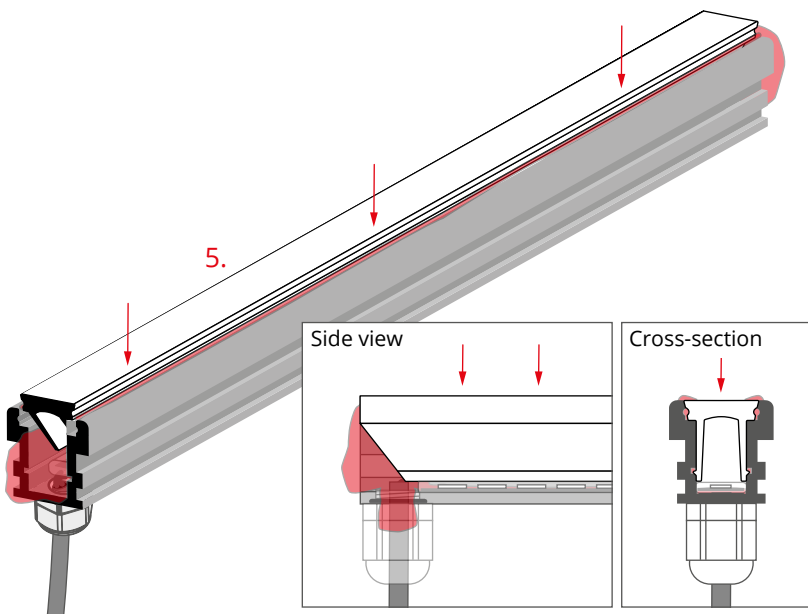

Mount the cover (5) in the profile and press it to the bottom. The excess silicone should come to the surface of the profile and out its ends.

XIII

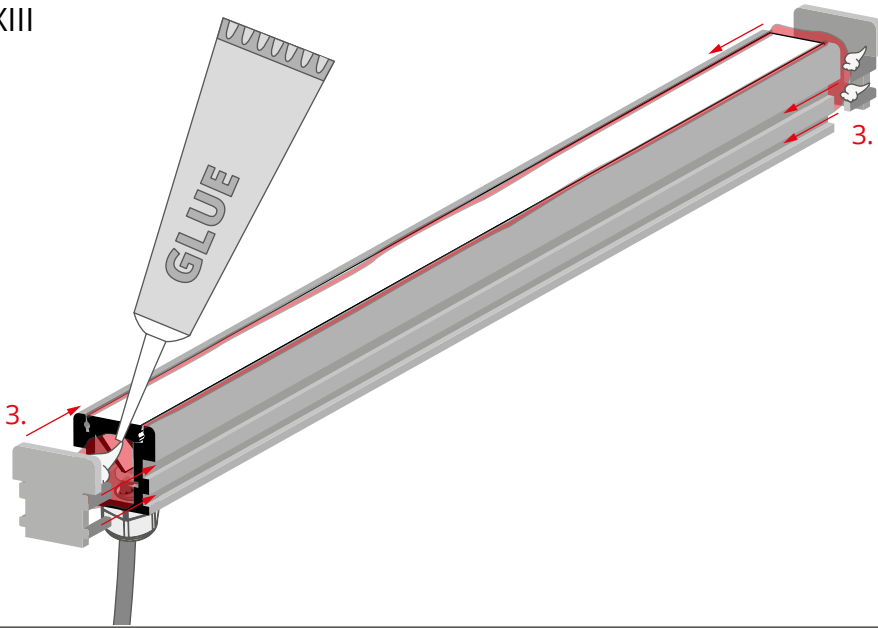

Adhere the end caps (3) into the profile.

XIV

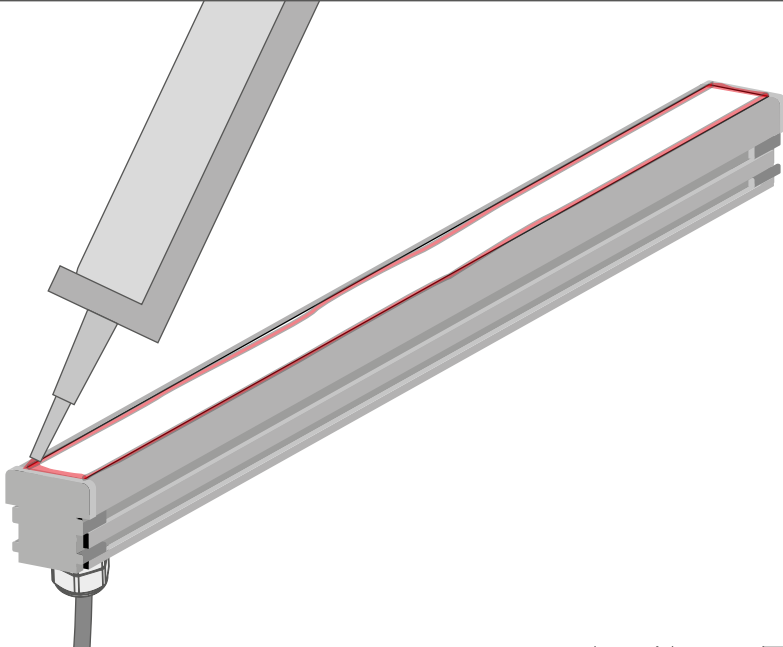

Distribute additional silicone to seal the gaps at the end caps.

XV

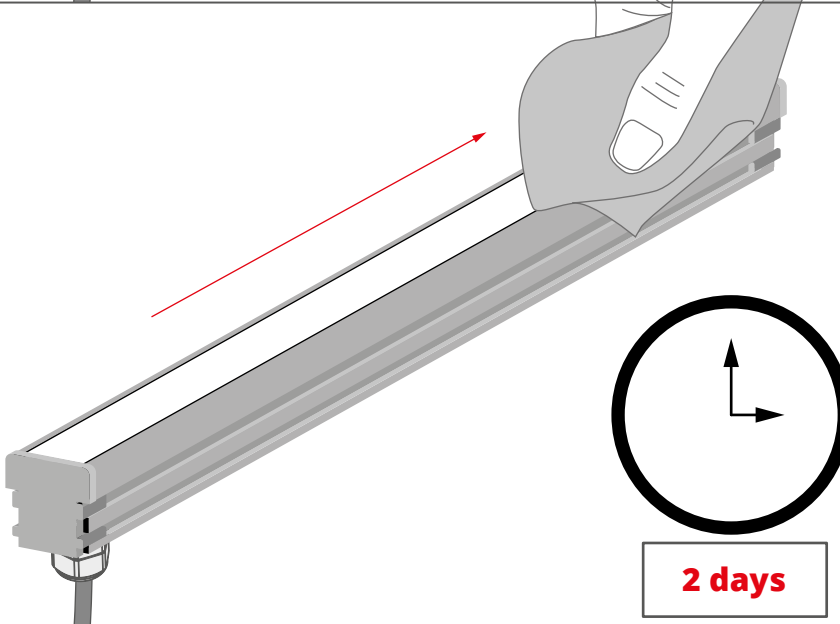

Wipe off the excess silicone from the surface and ends of the profile.
The curing time of the fixture is 2 days.

XVI OPTIONAL

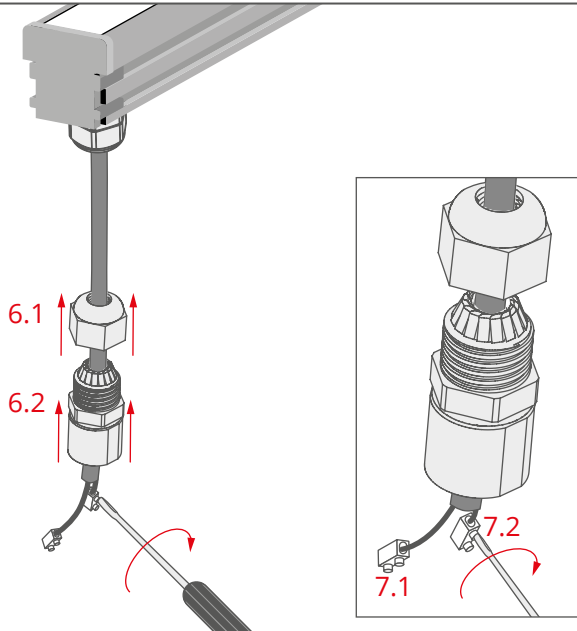

Put items (6.1, 6.2) of the hermetic coupler and both items of the connector (7.1, 7.2) on the cable.

NOTE! Connector items must be far enough not to touch each other when placed inside the coupler.

XVII OPTIONAL

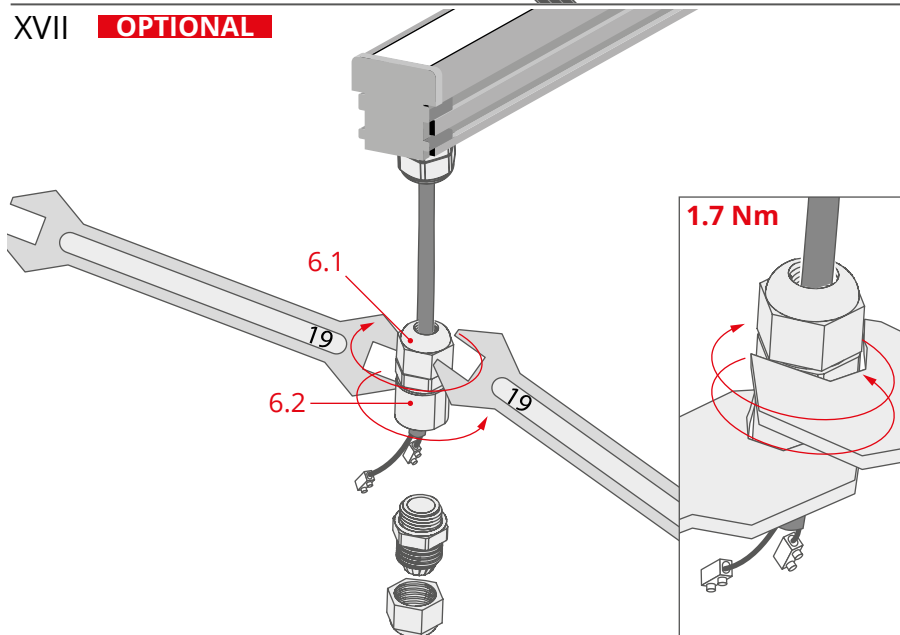

Tighten items (6.1, 6.2) of the hermetic coupler to lock them on the cable.

NOTE! The items must be tightened with torsional power equal to 1.7 Nm.

XVIII OPTIONAL

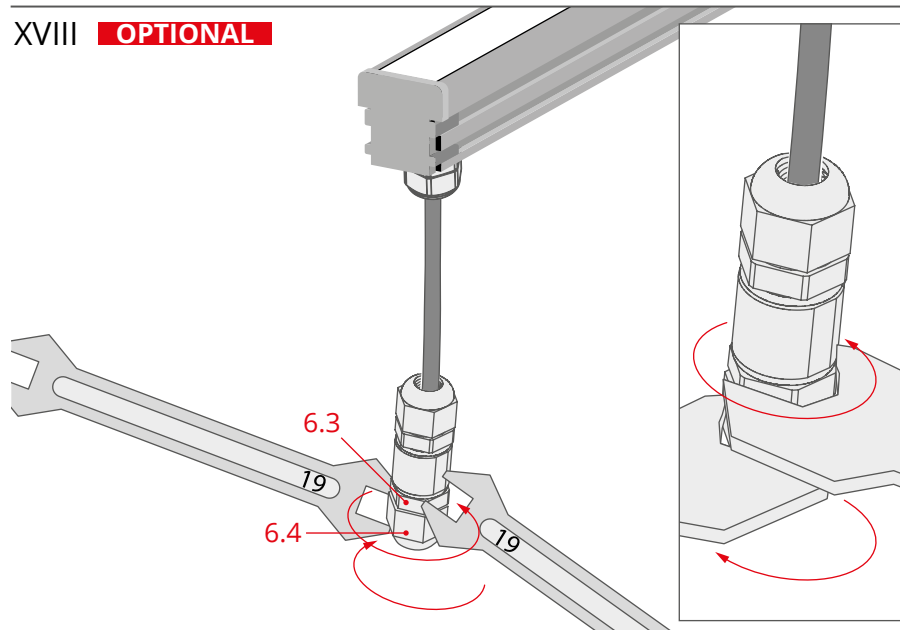

Add and tighten last two items of the hermetic coupler (6.3, 6.4).

Assembled fixture is now ready to be installed in the chosen surface.