

**Features :**

- 0/1-10V:100-264VAC, Triac: 170-264V
- Protection: Short circuit/overload/overvoltage
- Working temperature with 60°C
- Cooling by free air convection
- 100% full load burn-in test
- 3years warranty
- Support: TRIAC , Leading edge , Forward phase , Trailing edge, Reverse phase , 0/1-10V dimmable

Specification

CE RoHS BIS SELV IP67

	Model	HRSW-100-12	HRSW-100-24
Output	DC Voltage	12V	24V
	Voltage Tolerance	±0.5V	
	Rated Current	0 - 8.3A	0 - 4.2A
	Rated Power	100W	100W
	Ripple & Noise	150mVp-p	150mVp-p
Input	Voltage Range	0/1-10V:100-264VAC, Triac: 170-264V	
	Frequency Range	50 - 60HZ	
	Power Factor	PF ≥ 0.5/230VAC (Full loading)	
	Full Load Efficiency(Typ.)	86%	86%
	AC Current (Max.)	1.6A	1.6A
	Leakage Current	<0.5mA/260VAC	
	Inrush Current	≤ 60A	
Protection	Short Circuit	Protection type: Hiccup mode, recovers automatically after fault condition is removed.	
	Over Load	Hiccup mode, recovers automatically after fault condition is removed	
	VIBRATION	10-500Hz 2G10min	
	BURNT-IN TEST	Input voltage: 220V 50Hz rated output current 25°C Bum-in 2h	
Environment	Over Temperature	100°C±10°C shut down o/p voltage, re-power on to recover	
	Working TEMP.	-20 ~ + 50°C	
	Working Humidity	20~60%RH, non-condensing	
	Storage TEM., Humidity	-20~+ 85%, 10~95%RH	
	START RISE HOLD TIME	500ms, 20ms, 50ms/230VAC at full load	
Safety & EMC	Vibration	10 - 500Hz, 5G 12min./1 cycle, period for 60min. each along X, Y, Z axes.	
	Safety Standards	CE Mark	
	Withstand Voltage	I/P-O/P: 1.5KVAC I/P-GND: 1.5KVAC	
	EMC Immunity	EN55015:2013; EN61547:2009; EN61000-3-2:2014; EN61000-3-3:2013	
Others	Weight	0.65kg	
	Dimension	257x51x30mm (LxWxH)	
	Packing	30pcs/CTN	
Notes	<ol style="list-style-type: none"> 1. All parameters NOT specially mentioned are measured at 230VAC input , rated load and 25°C of ambient temperature. 2. Tolerance: includes set up tolerance, line regulation and load regulation . 3. The power supply is considered as a component that will be operated in combination with final Equipment. Since EMC performance will be affected by the complete installation, the final equipment manufactures must be-qualify EMC Directive on the complete installation again. 		

Mechanical Specification

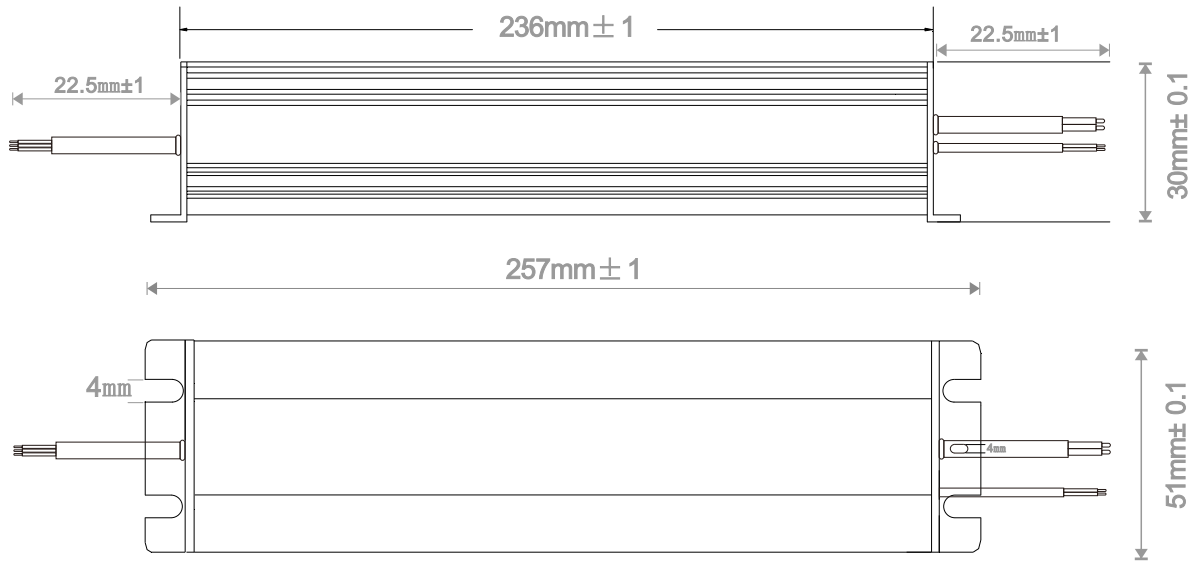

Derating Curve

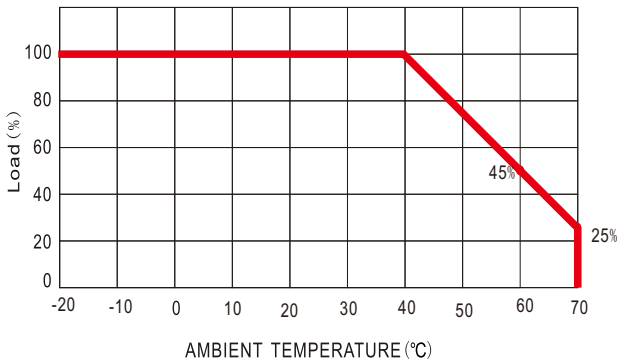

Package

DIMENSION	257x51x30 (mm) (L×W×H)
CARTON QUANTITY	30PCS/Cartron
CARTON SIZE	370x300x29.5 (mm)
WEIGHT	650g/PCS

Switching Time Curve:

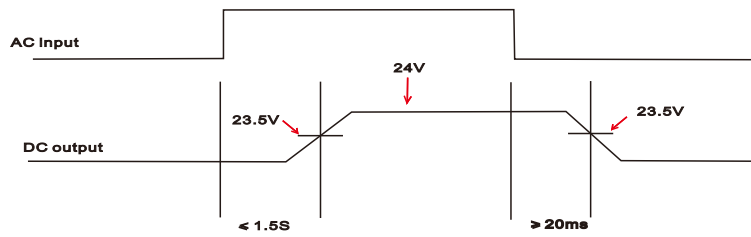

Dimming Operation

