

STEP LIGHT SQUARE

ΠΕΡΙΕΧΟΜΕΝΑ / CONTENTS

Datasheet	1
Manual	3

SKU: STPS-XX-XX



DATASHEET

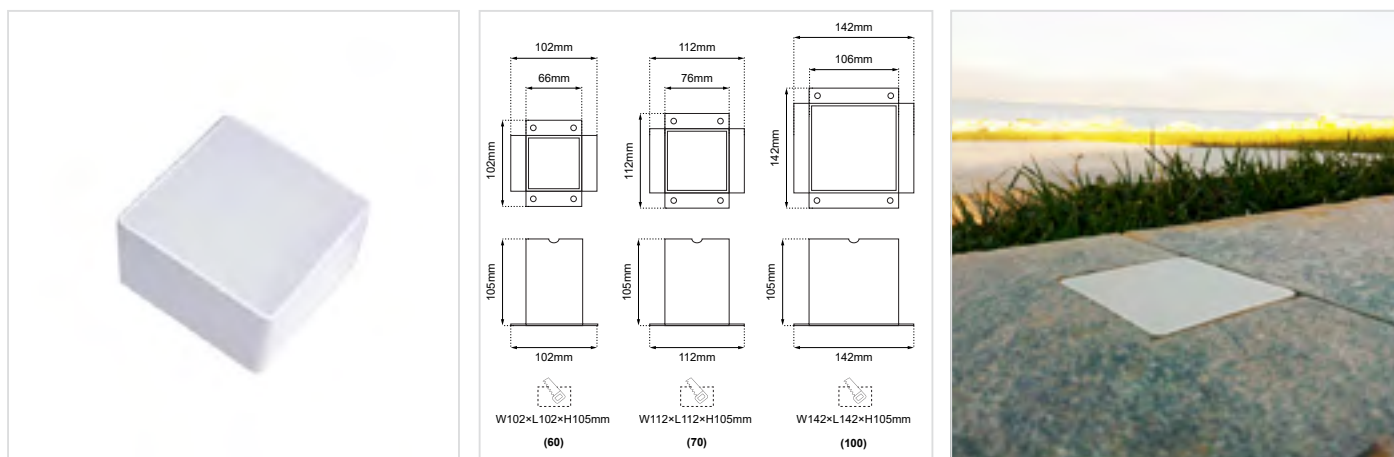

GENERAL INFORMATION

APPLICATION	Outdoor
DIRECTION OF MOUNTING	Ground
MATERIAL	Inox
COLOR	White
IP CLASSIFICATION	IP68
INCL. CABLE	No
ELECTRIC GEAR	Not included
WEIGHT	250gr (60x60cm) 350gr (70x70cm) 450gr (100x100cm)
LIFE TIME	50000 hours
WARRANTY	3 years
ORIGIN	Greece







ILLUMINANT

LED TYPE	Osram
CRI	Ra80
WATTAGE	1W
VOLTAGE	24VDC
CONNECTION	Parallel
INCL. CABLE	No
ELECTRIC GEAR	Not included

STEP LIGHT SQUARE DATASHEET

SKU: STPS- XX-XX

DIMENSIONS
CCT

Dimensions (W×L×H)*	CCT*
60 × 60 × 70cm (60)	2700K (27K) 
70 × 70 × 70cm (70)	3000K (30K) 
100 × 100 × 70cm (100)	4000K (40K) 
	6000K (60K) 
	(R) / (G) / (B) / (A) 
	RGB (C1) 

* Υποχρεωτική επιλογή / Mandatory option

Δημιουργία Κωδικού προϊόντος / Product Code generator

STPS- dimensions - CCT

EXAMPLE:

STPS - 60-27K

for STEP LIGHT SQUARE, 60 × 60 × 70cm, 2700K

ΒΑΣΗ ΣΤΗΡΙΞΗΣ ΤΟΥ ΦΩΤΙΣΤΙΚΟΥ LUMINAIRE SUPPORT BOX

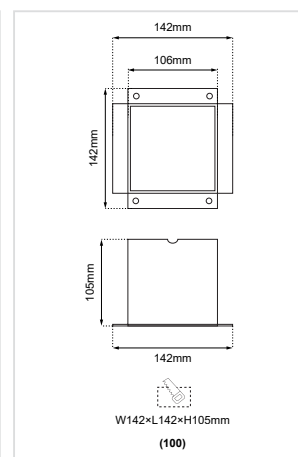
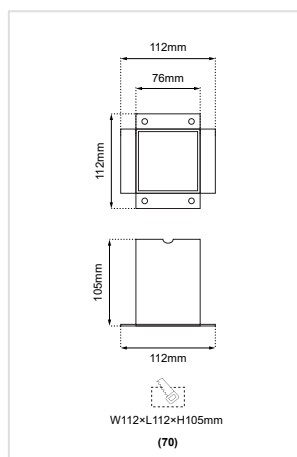
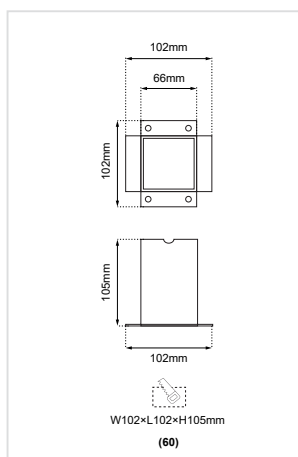

STEP LIGHT SQUARE dimensions (W×L×H)	Support box dimensions (W×L×H)	Cut-out dimensions (W×L×H)
60 × 60 × 70cm (60)	102 × 102 × 105cm	102 × 102 × 105cm
70 × 70 × 70cm (70)	112 × 112 × 105cm	112 × 112 × 105cm
100 × 100 × 70cm (100)	142 × 142 × 105cm	142 × 142 × 105cm

STEP LIGHT SQUARE MANUAL

ΟΔΗΓΙΕΣ ΕΓΚΑΤΑΣΤΑΣΗΣ INSTALLATION INSTRUCTIONS

1. ΠΡΟΕΤΟΙΜΑΣΙΑ ΤΟΥ ΕΔΑΦΟΥΣ
2. ΕΦΑΡΜΟΓΗ ΒΑΣΗΣ ΦΩΤΙΣΤΙΚΟΥ ΣΤΟ ΕΔΑΦΟΣ
3. ΕΦΑΡΜΟΓΗ ΥΛΙΚΟΥ ΕΠΙΦΑΝΕΙΑΣ ΓΥΡΩ ΑΠΟ ΤΟ ΦΩΤΙΣΤΙΚΟ
4. ΚΑΝΕΤΕ ΤΗΝ ΗΛΕΚΤΡΙΚΗ ΣΥΝΔΕΣΗ
5. ΤΟΠΟΘΕΤΗΣΗ ΤΟΥ ΦΩΤΙΣΤΙΚΟΥ

1. PREPARATION OF TERRAIN
2. APPLICATION OF BASE ON THE GROUND
3. APPLICATION OF SURFACE MATERIAL AROUND THE LIGHTING
4. MAKE THE ELECTRICAL CONNECTION
5. PLACE THE LUMINAIRE

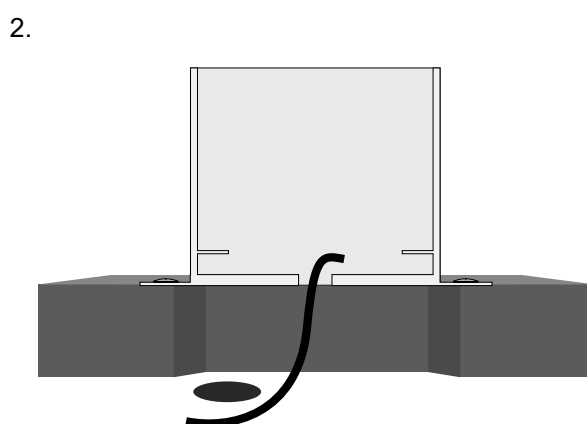
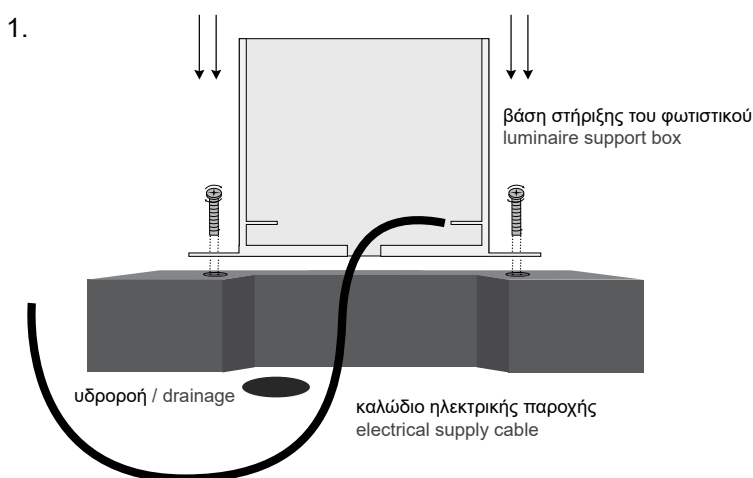

Βιδώνετε την βάση στήριξης του φωτιστικού στο έδαφος μέχρι να σταθεροποιηθεί.
Use screws to apply and stabilize the luminaire's support box to the ground.

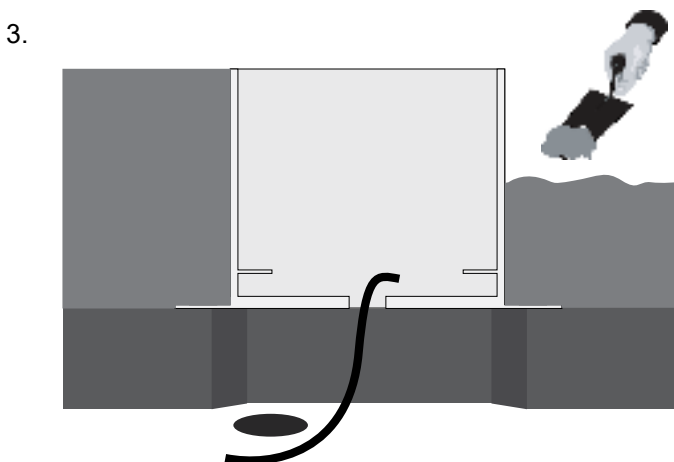

Τοποθετείτε το υλικό που θα καλύψει την επιφάνεια του χώρου σας γύρω από το φωτιστικό.
Apply the material that will cover the surface of your indoor or outdoor spaces around the luminaire.

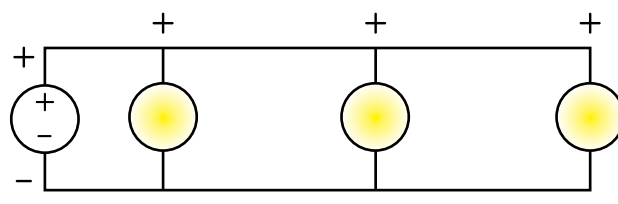
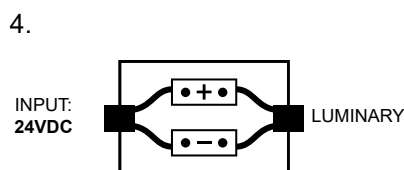

Συνδέστε το καλώδιο του φωτιστικού με την ηλεκτρική παροχή.
Η σύνδεση πρέπει να είναι στεγανή.
Connect the cable of the luminaire with the electrical supply.
The connection must be sealed.

Η εγκατάσταση του προϊόντος πρέπει να γίνεται από αδειούχο ηλεκτρολόγο εγκαταστάτη. / The product must be installed by a licensed electrical installer.

STEP LIGHT SQUARE MANUAL

5.

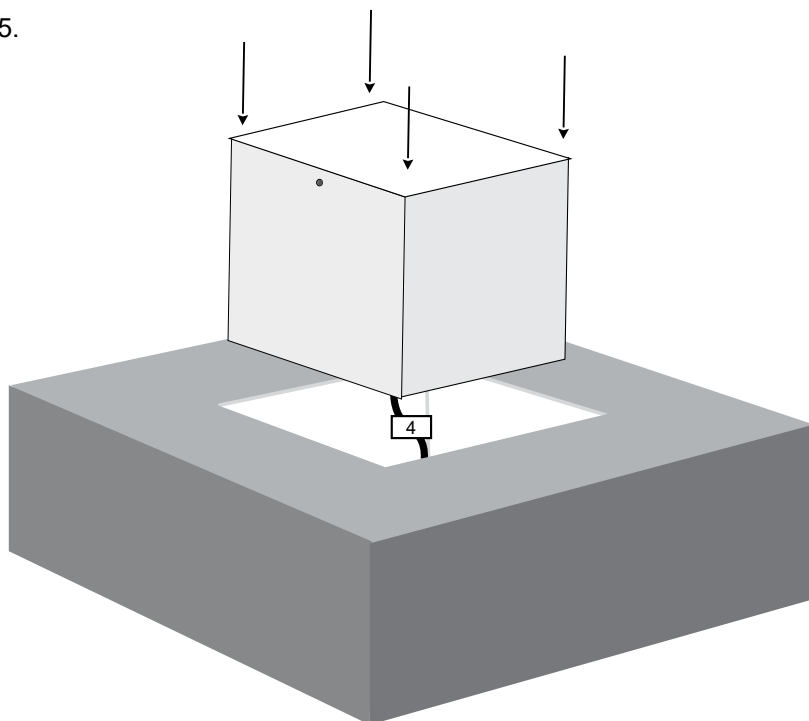

Τοποθετείτε το φωτιστικό στη βάση.
Place the luminaire on the base.

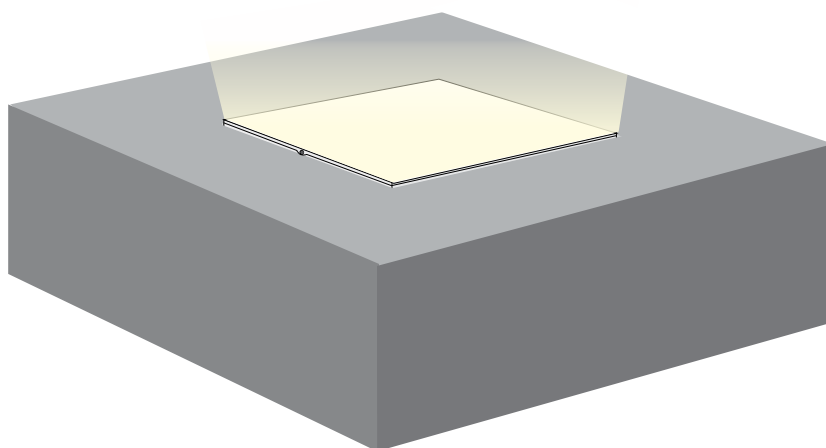

Το φωτιστικό είναι έτοιμο για χρήση.
The luminaire is ready to be used.